

MIKON
MACHINERY

VESTA PRO

CNC
ROUTER

CNC FREZE

www.mikonmachinery.com



**AUTOMATIC
LOADING
UNIT**



**NESTING &
MILLING**



**UNLOADING
UNIT**



Automatic
NESTING, MILLING &
DRILLING

LINE

www.mikonmachinery.com

PRESSER ROLLER UNIT

Presser Roller Unit allows you to cut more than one boards at a time (stacked boards) during nesting operations.

Automatically positionable pressure rollers with linear slides automatically switch to the deactivated position during hole drilling operations, providing ease of work.

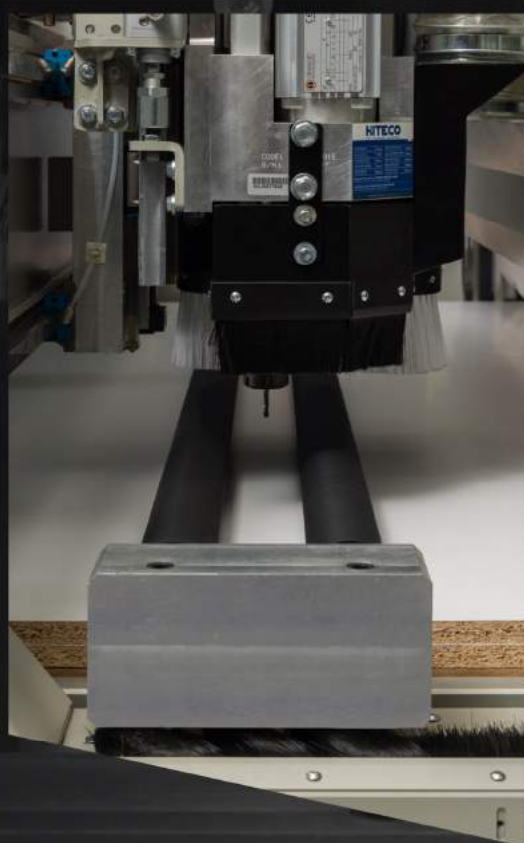

VESTA PRO

It is a fully automatic production line designed for companies engaged in mass production. It is designed to provide high-level solutions by increasing efficiency in production. It carries out all production automatically with loading and unloading units and minimizes the need for extra operators.

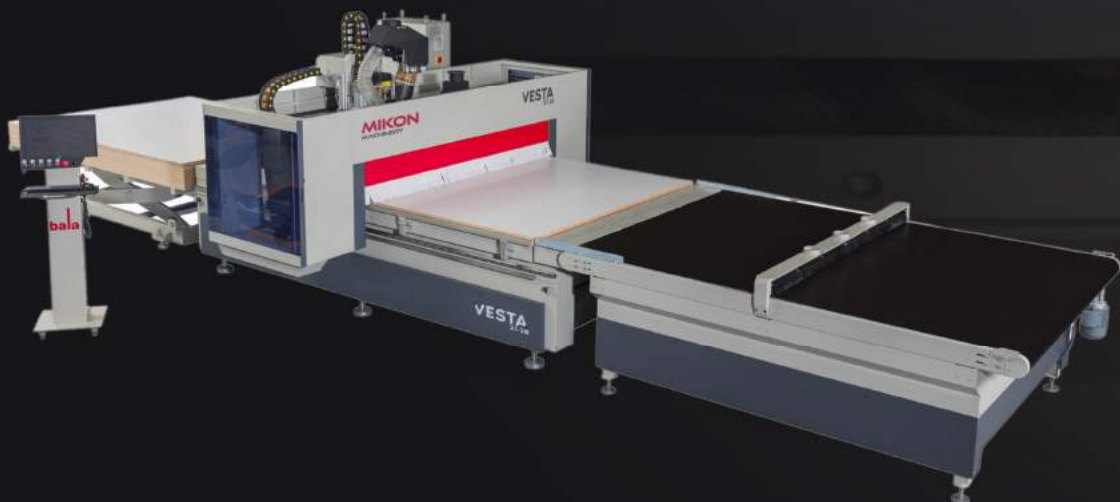

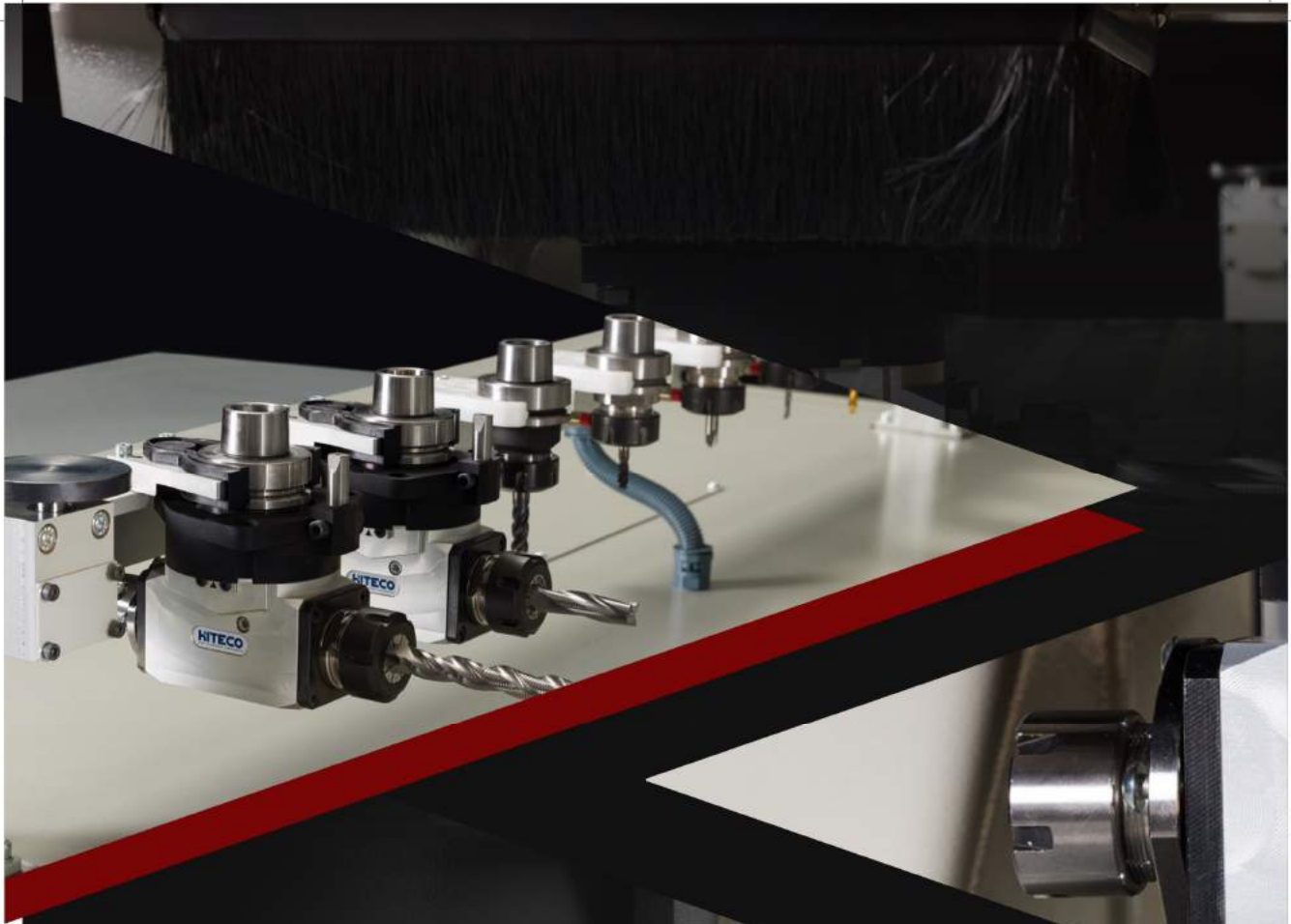

Vertical Drilling Unit

Drilling group of 9 vertical spindles with 32 mm spacing.

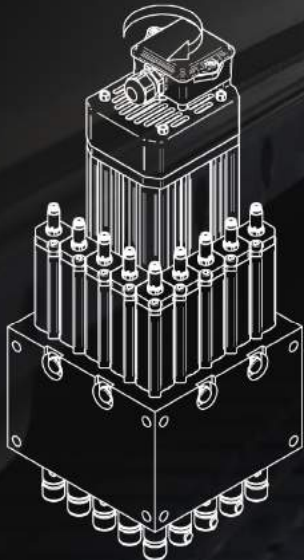

www.mikonmachinery.com

Flexible with Aggregate Unit

With its double tool output and ER25 connection, the aggregate system offers special use for your door lock and hinge operations.

HITECO
HIGH TECHNOLOGY COMPONENTS

www.mikonmachinery.com

Automatic Tool Changer

It is a system that provides the opportunity to change tools without wasting time in Nesting and Milling operations.



Customizable Vacuum Zones

The machine work table can be divided into multiple vacuum zones according to your needs. Multiple vacuum zones provide a stronger grip in your operations and prevent part slippage.

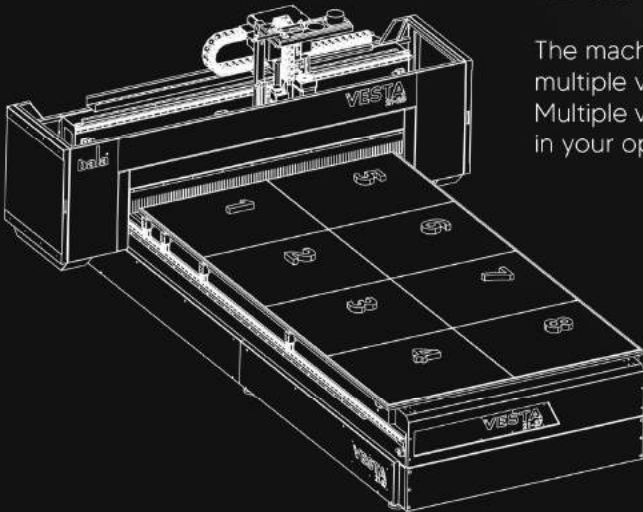

Automatic Tool Length Measurement

Automatic Tool Length Measurement ensures more automated and seamless operations. Otomatik Takım Boyu ölçme daha hassas ve daha doğru işlemlere olanak sağlar.

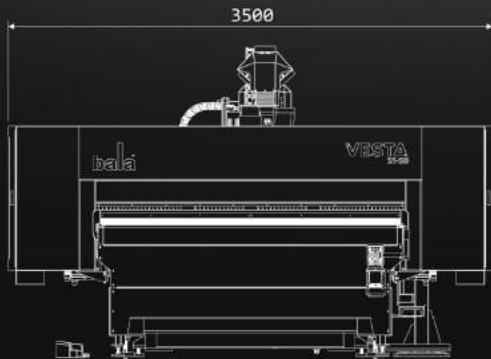
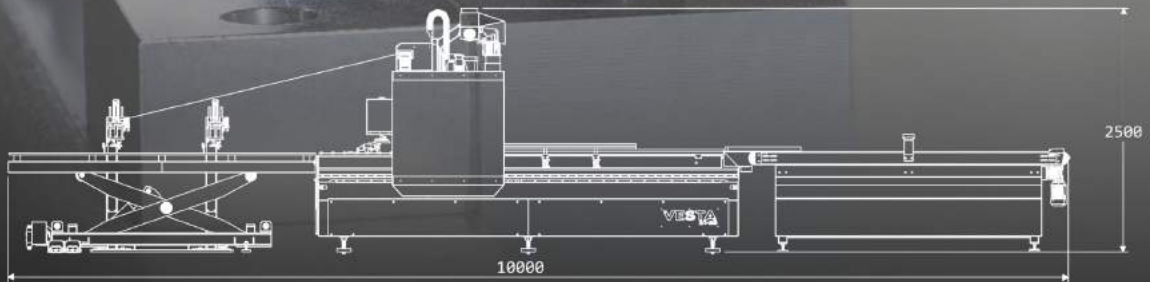

TEKNİK ÖZELLİLER	
Working Capacity	2100x3700 or 2100x2800 mm
Table	Phenolic
X Axis speed	70m/min
Y Axis Speed	70m/min
Z Axis speed	20 m/min
Travel of Z axis	300mm
Router motor	8-11 kW
Router speed (max)	24,000 RPM
Automatic Tool Change Positions	10
Vacuum	Dry type / 250 m3
Vacuum Area	6-8
CAD/CAM Program	Alphacam 3D
Installed Power	30 kW
Approx Weight	4,200 Kg

VESTA PRO

Our company takes part in wood processing sector from 1992; keeps providing the best service to its customers, with the great "dealer's network" and after sales support service at different 57 points in the world. In our manufacturing facility with a closed area of 12.000 m2 in Inegöl /Bursa; We produce new generation furniture production machines and furniture packaging machines. Bala Makina, which has been developing and growing for 30 years; will continue to produce new generation technologies using advanced production techniques.

MIKON
MACHINERY

☎ (844) 579-8398

✉ sales@mikonmachinery.com

📍 967 Edgeley Blvd. Vaughan, ON L4K 5Z4

🌐 www.mikonmachinery.com